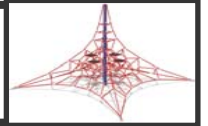




**THE JUMPING SPIDER MODEL NO.  
INSTALLATION MANUAL**

**1102**



**DYNAMO INDUSTRIES**

880 Taylor Creek Dr., Ste. 122

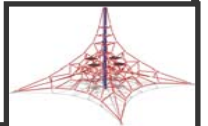
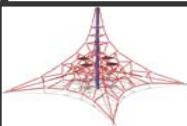
Ottawa, ON K1C 1T1

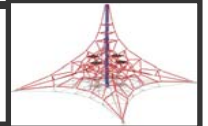
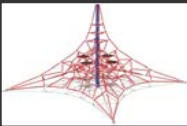
Canada

Toll free: (800) 790-0034 (Canada & US)

Local: (613) 845-0910

Fax: (613) 845-0914





## Features

The Jumping Spider is a specialty climbing structure featuring a flexible center area surrounded by netting. It is made of steel-loaded Nylon cables with UV guard and the landing surface is a textile-reinforced flexible rubber material.

The 1102 features **Dynamo DX technology** which includes the highest steel content and the strongest connection materials in the industry, including a steel-wire core in our edge ropes and connection points crushed in place with over 75 tons of pressure to ensure long life of the games and maximum safety for the children.

Dynamo Nets help bring movement, balance, exercise and fun back into the playground.

**Ages: 2 to 12 years**

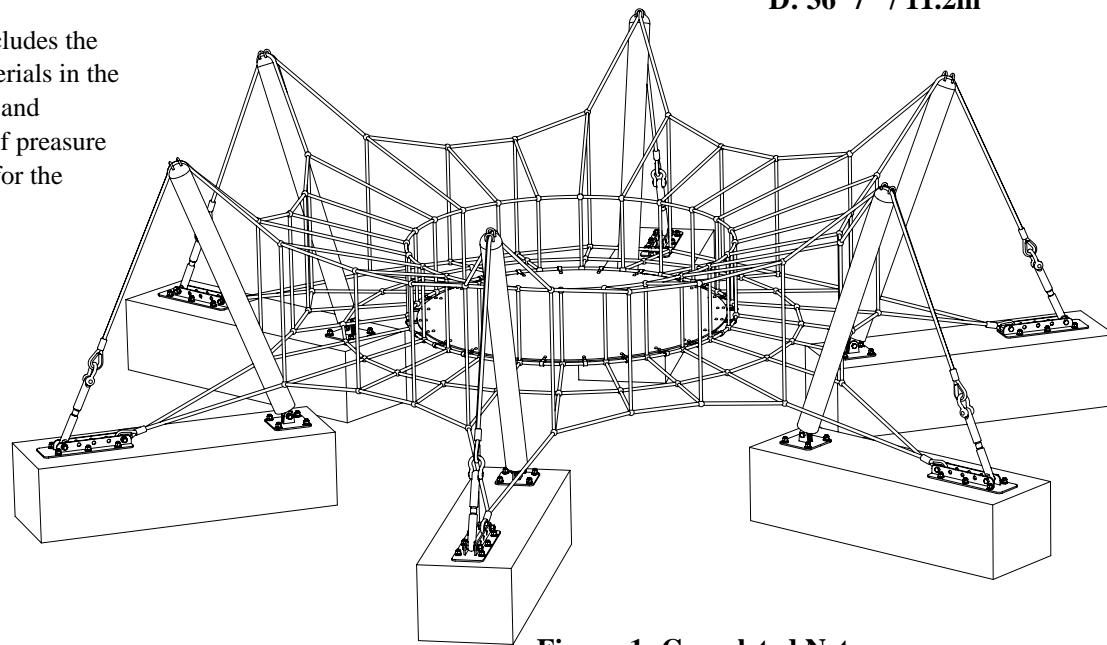
**Capacity: 11 children**

**Size: D: 24' 7" / 7.5m**

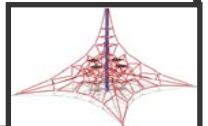
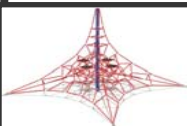
**H: 4' 11" / 1.5m**

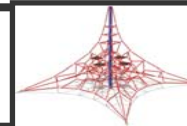
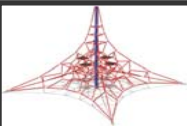
**Use zone:**

**D: 36' 7" / 11.2m**



**Figure-1: Completed Net**





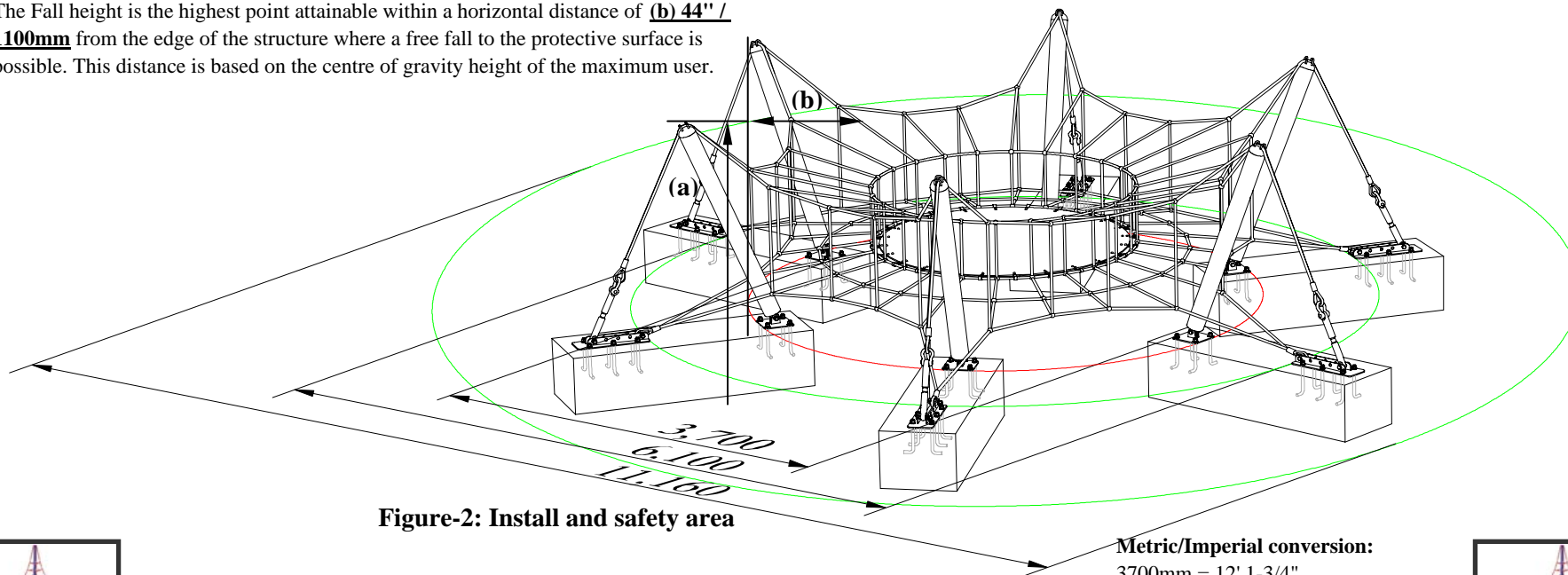
**Safety area**

The requirements for space and safety clearances are taken from BS-EN 1176-1 / ASTM-F1487 / CSA Z614

The use zone for stationary play equipment shall extend no less than 72 in. (1830mm) from all sides of the play structure.

**Fall Height : (a) 4' 11" / 1500mm (from surface)**

The Fall height is the highest point attainable within a horizontal distance of **(b) 44" / 1100mm** from the edge of the structure where a free fall to the protective surface is possible. This distance is based on the centre of gravity height of the maximum user.



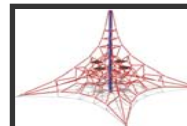
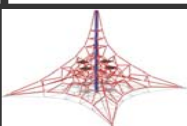
**Figure-2: Install and safety area**

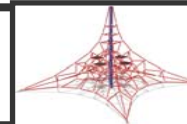
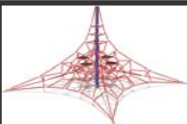
**Metric/Imperial conversion:**

3700mm = 12' 1-3/4"

6100mm = 20' 0-1/4"

11160mm = 36' 7-1/4"

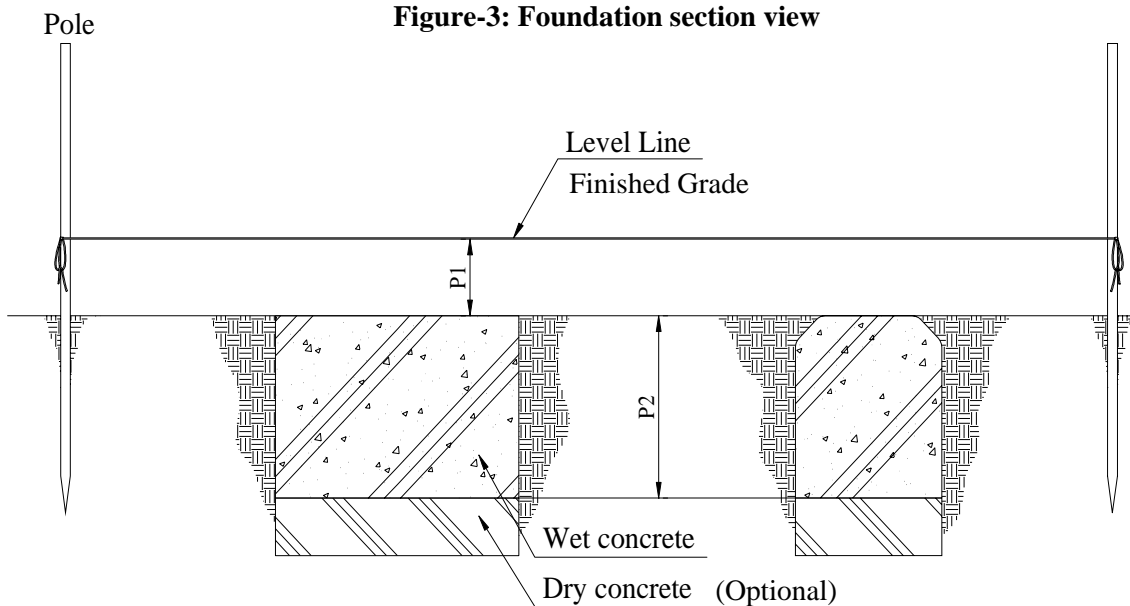




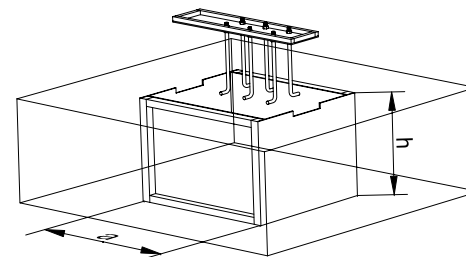
### Foundation

Please refer to #1102 drawing for exact installation dimensions

**Figure-3: Foundation section view**



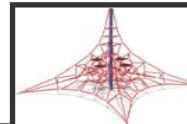
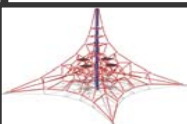
**P1 = Depth below finished Grade (12" / 300mm)**  
**P2 = Depth of concrete footing (19-2/3" / 500mm)**

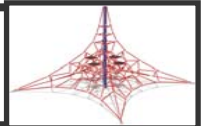
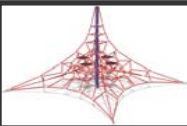


**Figure-4 : Excavate enough materials to allow for proper depth of concrete footings**

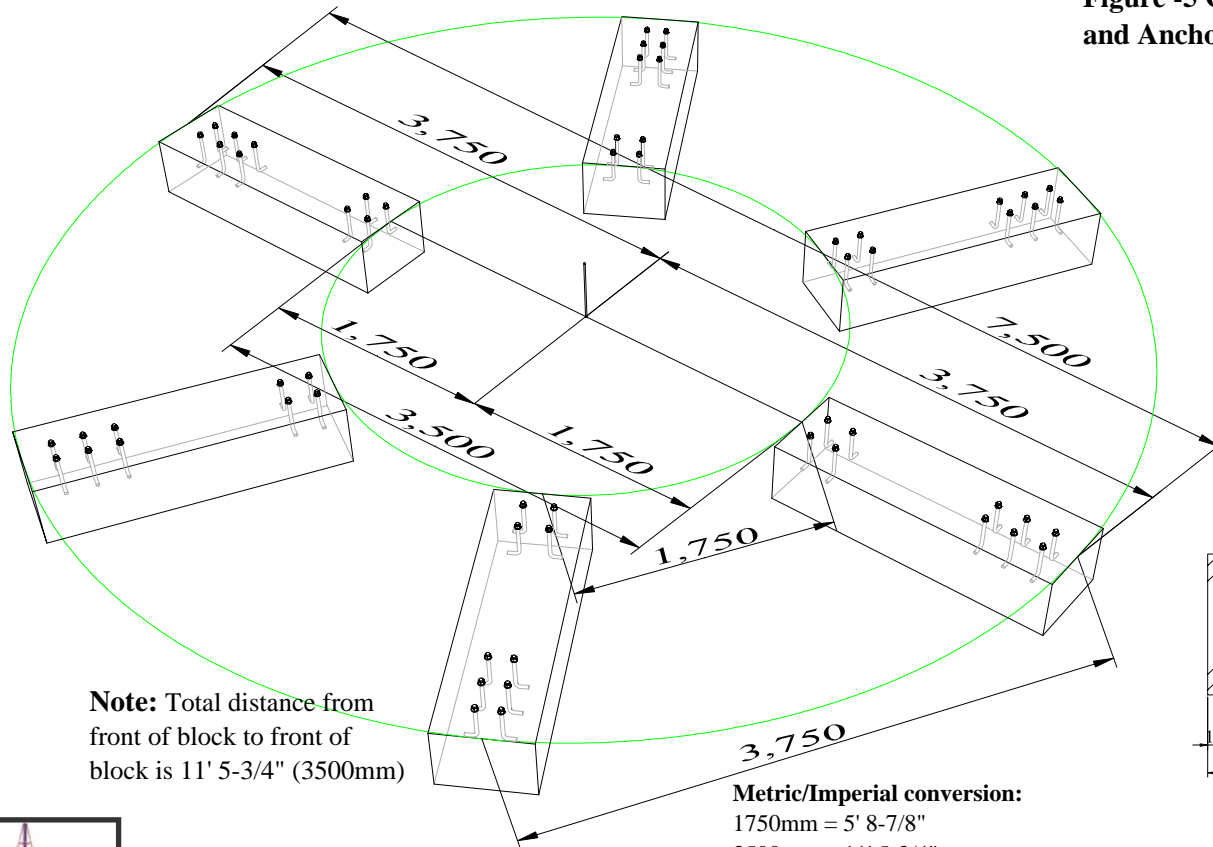
Also ensure that there is enough space to allow the frame to be positioned properly.

Anchor wood support frame to ground with pickets to prevent the frame from moving while concrete is poured and sets.





**Figure -5 Concrete footing and Anchor plate Layout**

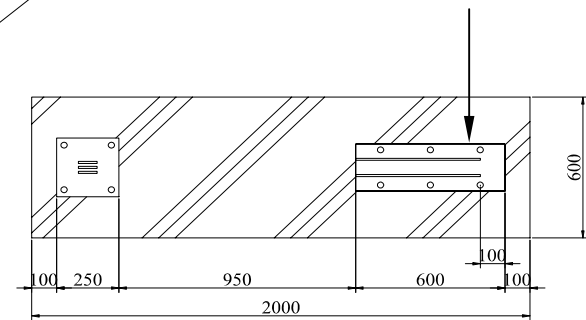


**Note:** Total distance from front of block to front of block is 11' 5-3/4" (3500mm)

**Metric/Imperial conversion:**

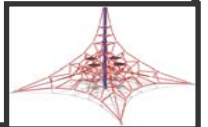
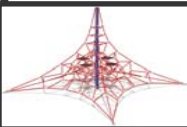
1750mm = 5' 8-7/8"  
 3500mm = 11' 5-3/4"  
 3750mm = 12' 3-5/8"  
 7500mm = 24' 7-1/4"

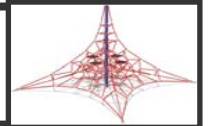
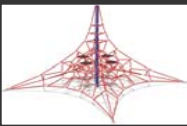
**Positioning Anchor plate on footing**  
 [CF] 'L' anchor hole  
 Front edge of anchor plate must be installed 4" / 100mm from edge of concrete footing.



**Metric/Imperial conversion:**

100mm = 4"      950mm = 3' 1-3/8"  
 250mm = 9-7/8"      2000mm = 6' 6-3/4"  
 600mm = 1' 11-1/2"





Assemble wooden support frames \*  
6 frames (78-3/4" / 2000mm L x 23-2/3" / 600mm W x 19-2/3" / 500mm H)  
\*Use 1/2" (min) plywood; not included in package

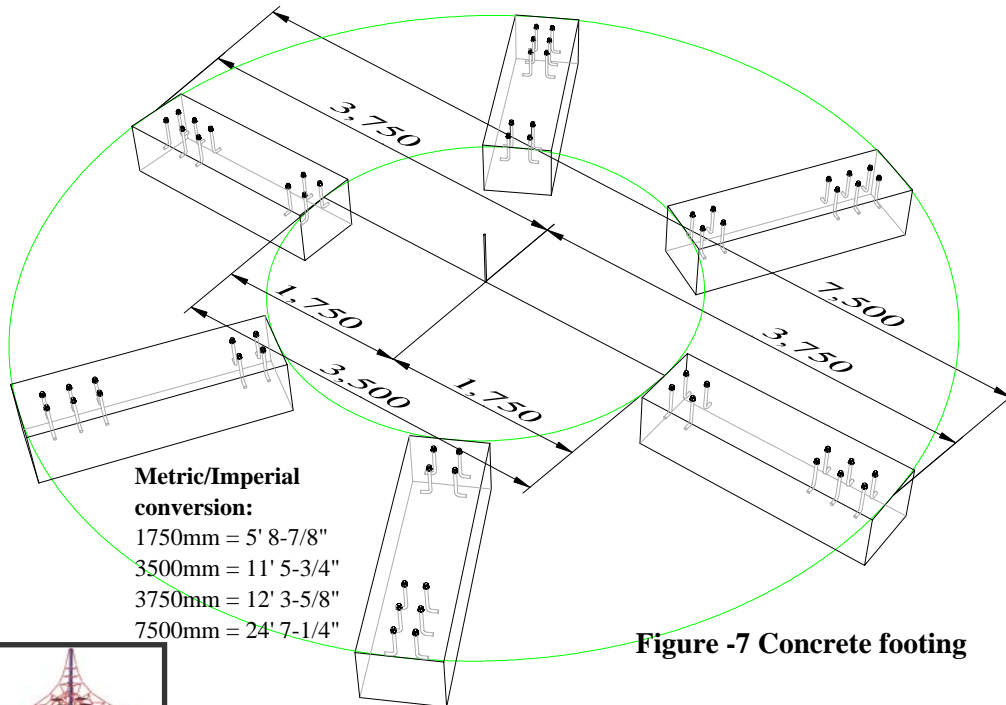
**Concrete**

Pour concrete\* into wooden support frame until flush to top edge  
Allow 3-5 days for concrete to cure before proceeding to next step.

\*Concrete is to be wet concrete with minimum 25 MPa / 3500 PSI.

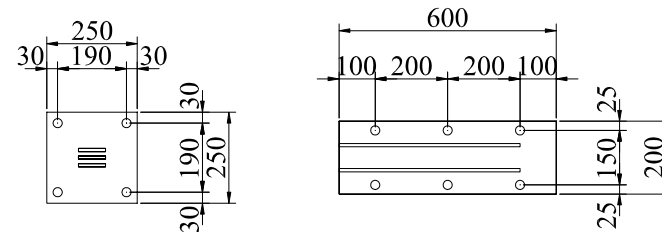
**Remove wood support frame from dry concrete blocks**

After concrete has cured enough, remove frame and replace soil in area around footing to subgrade level



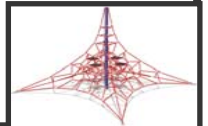
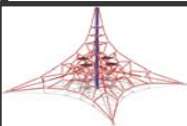
**Metric/Imperial conversion:**  
1750mm = 5' 8-7/8"  
3500mm = 11' 5-3/4"  
3750mm = 12' 3-5/8"  
7500mm = 24' 7-1/4"

**Figure -7 Concrete footing**

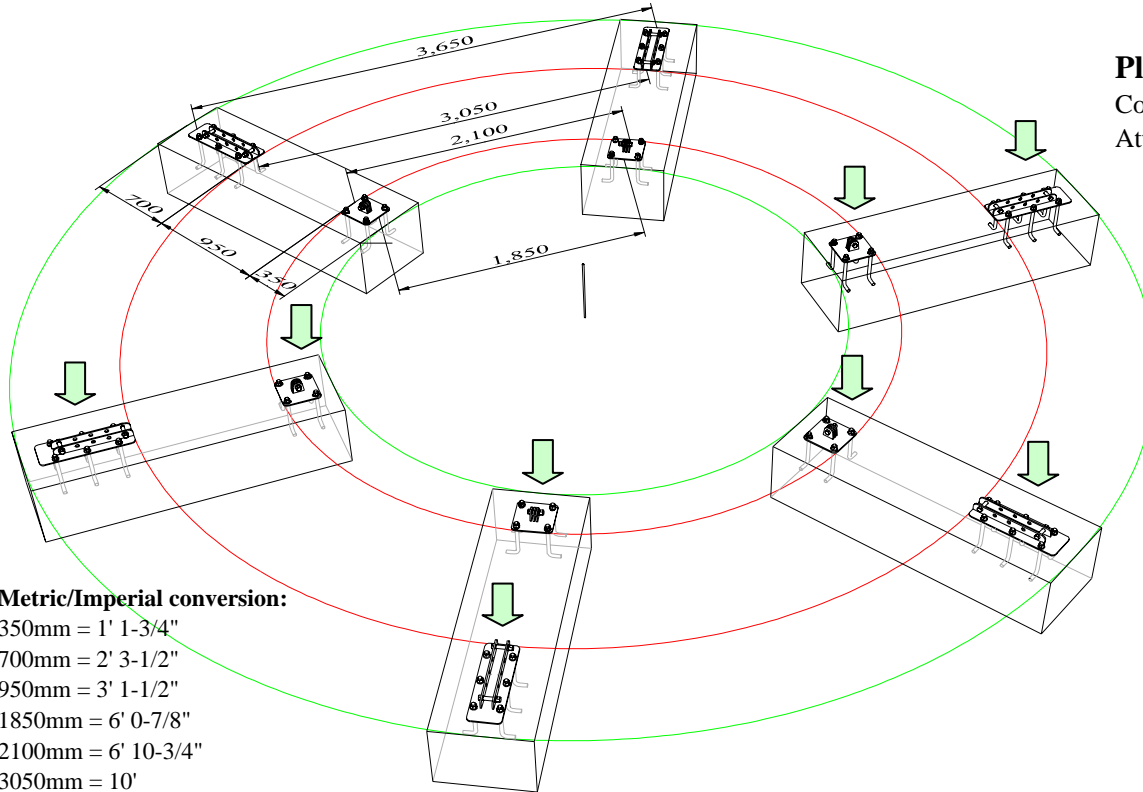
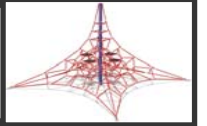
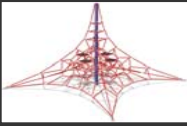


**NOTE:** Use anchor plate as guide for exact measurements.

**Metric/Imperial conversion:**  
25mm / 30mm = 1"    200mm = 7-7/8"  
100mm = 4"    250mm = 9-7/8"  
150mm = 6"    600mm = 1' 11-1/2"  
190mm = 7-1/2"





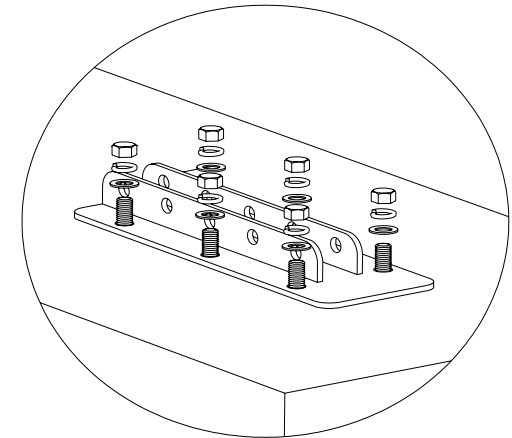


**Metric/Imperial conversion:**

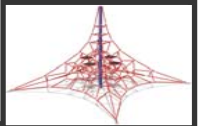
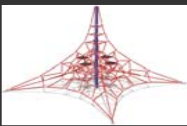
- 350mm = 1' 1-3/4"
- 700mm = 2' 3-1/2"
- 950mm = 3' 1-1/2"
- 1850mm = 6' 0-7/8"
- 2100mm = 6' 10-3/4"
- 3050mm = 10'
- 3650mm = 11' 11-3/4"

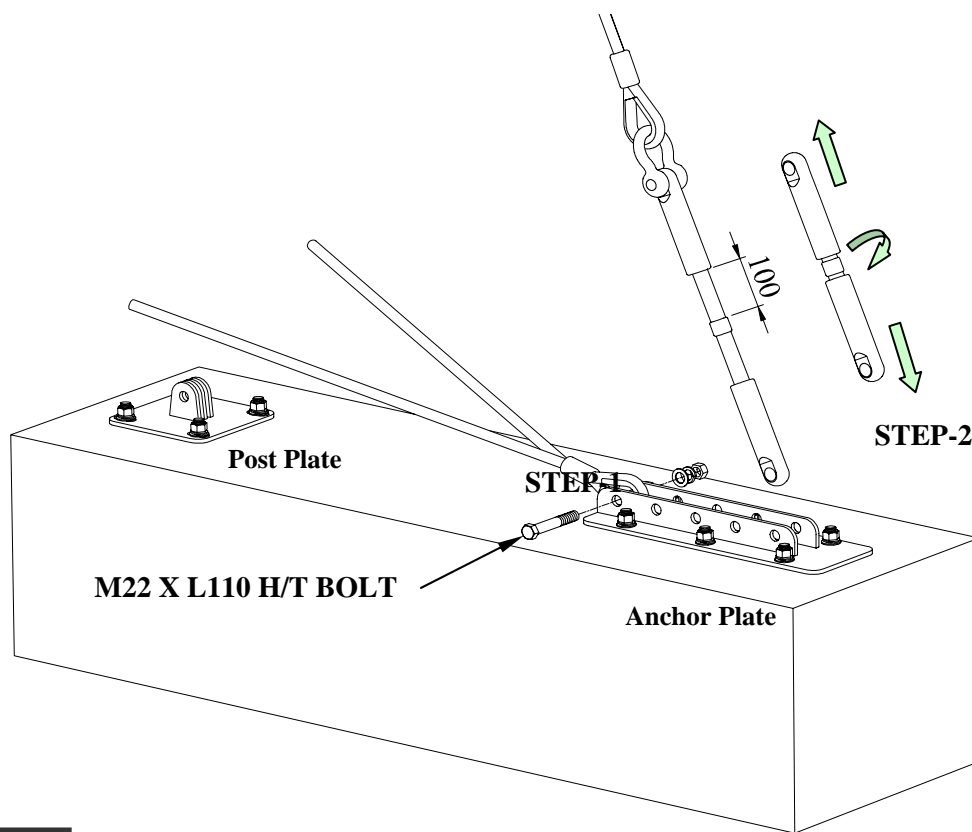
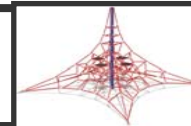
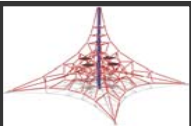
**Plate Assembly**

Concrete block-clean threads of "L" anchor bolts.  
Attach Anchor plate to footing



**Figure-8: Attach Anchor plate to footing with flat washer, locking washer and nut.**





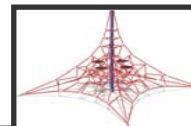
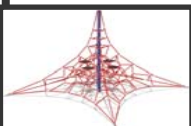
**Main rope assembly**

Step 1: Attach bottom rope with M22 X L110 H/T BOLT as shown in Figure 9

Step 2: Attach Turnbuckle to anchor plate with M22 X L110 H/T BOLT.

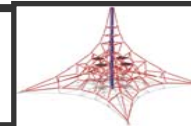
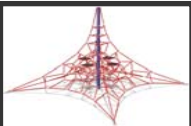
Loosen Turnbuckle all the way (about 100mm), leaving only 4 or 5 threads attached

**Figure-9: Attach Turnbuckle and rope**

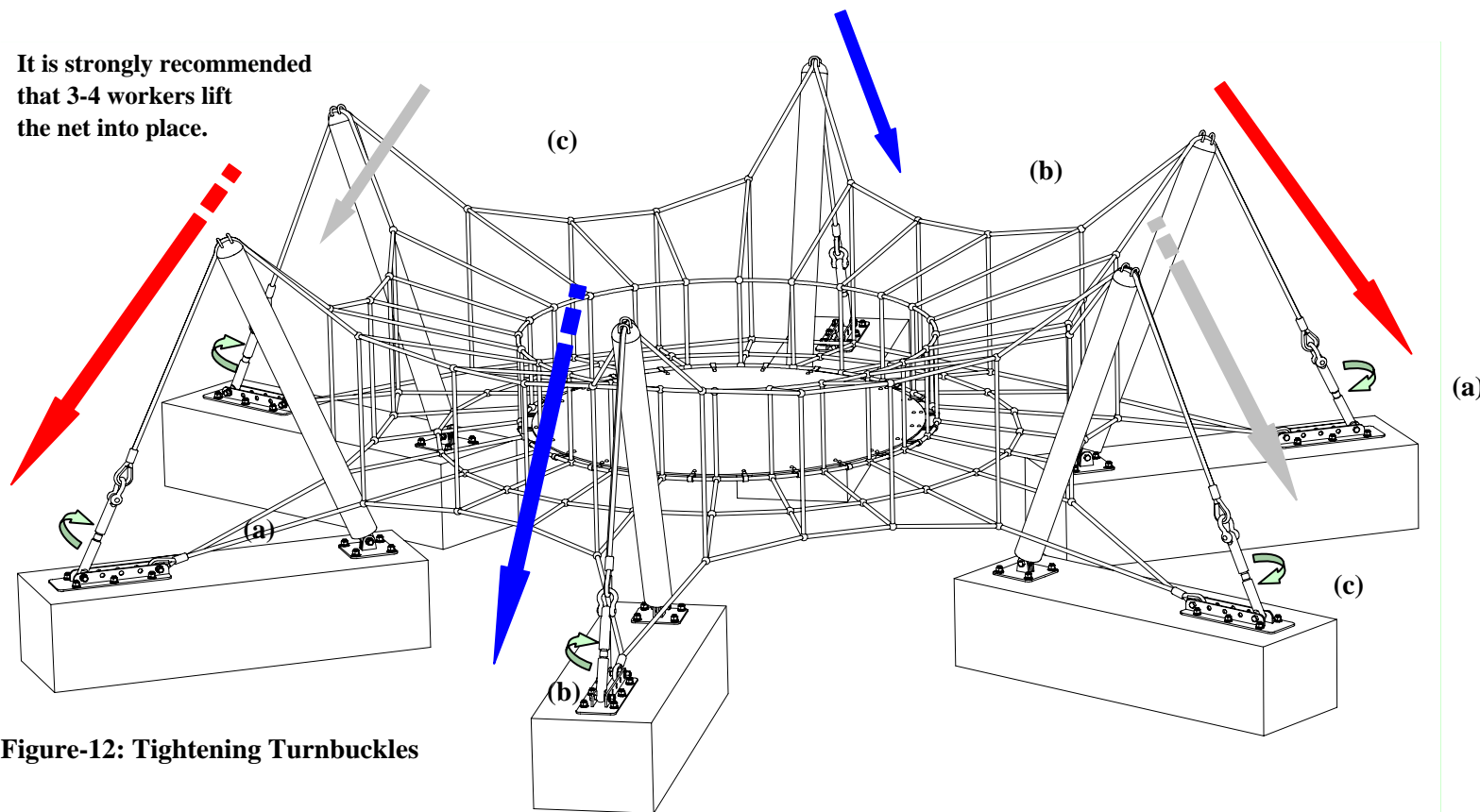






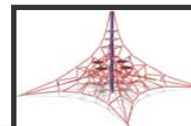
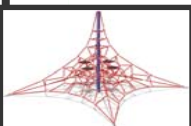


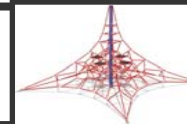
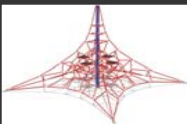
It is strongly recommended that 3-4 workers lift the net into place.



**Figure-12: Tightening Turnbuckles**

Tighten all Turnbuckles in pairs evenly until net is tight.





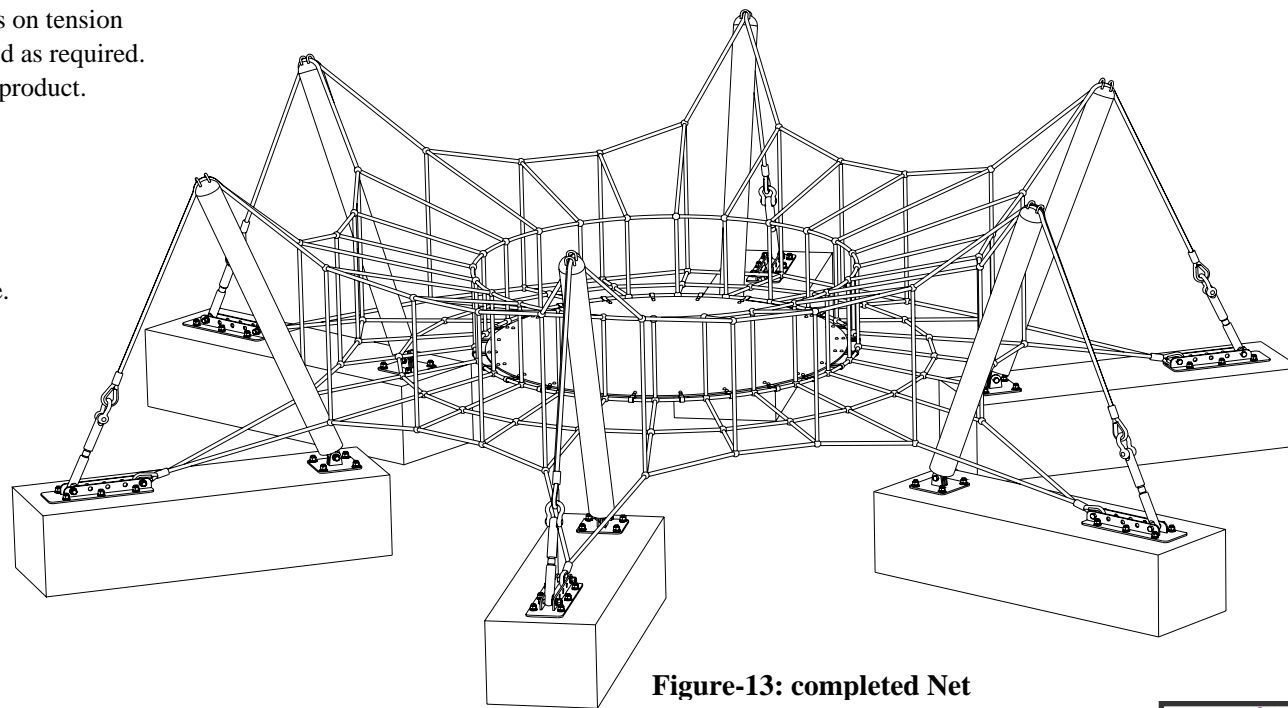
### Maintenance information

Please tighten rope with Turnbuckle properly.  
If you tighten the net too much, it may damage the net.  
It is also recommended that subsequent checks on tension be carried out at monthly intervals and adjusted as required.  
This will increase the overall longevity of the product.

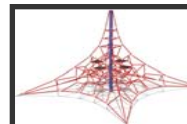
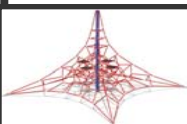
#### Checking: 1 month

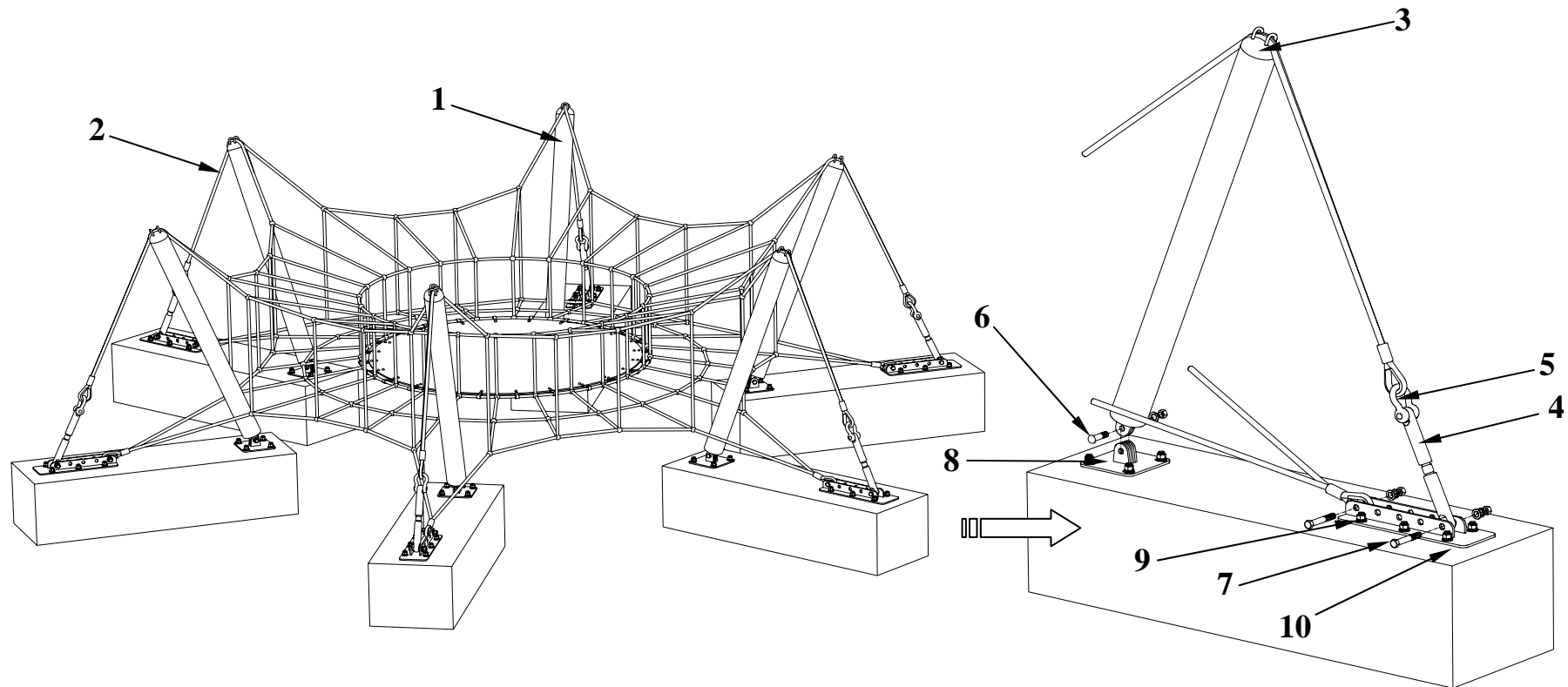
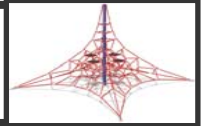
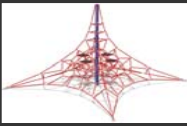
Refer to IPEMA and TUV maintenance system.

After properly tensioning the net, it will stretch slightly over the first four weeks of use.  
Following this initial period, the net needs to be fully re-tensioned by Turnbuckle after 1 year.



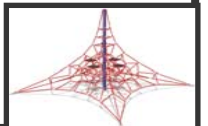
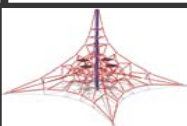
**Figure-13: completed Net**

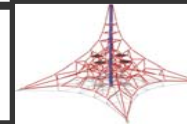
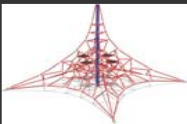




- 1: main post
- 2: multi compound rope
- 3: post cap
- 4: turn buckle
- 5: anchor shackle

- 6: T/S bolt,nut, washer
- 7: H/T bolt,nut, washer
- 8: post plate
- 9: L-anchor bolt,nut,washer
- 10: Anchor plate





**A weekly check of the activity net is recommended to ensure that no acts of vandalism have damaged the rope. Periodic checks on tension will assist in the durability of the product.**

